

Flat Top Conveyor Sprockets

815 Flat Top Conveyor Sprocket

NOTE!
UHMW-PE Nat. (White)

P/N	Teeth(Actual)(Effective)	Pitch Dia.	Outside Dia.	Bore(Stock)(Max.)
815FT19	19 9-1/2	4.620"	4.610"	3/4" 1-1/4"
815FT20	20 10	4.854"	4.860"	3/4" 1-1/4"
815FT21	21 10-1/2	5.089"	5.120"	3/4" 1-3/4"
815FT22	22 11	5.324"	5.350"	3/4" 1-3/4"
815FT23	23 11-1/2	5.560"	5.590"	3/4" 1-3/4"
815FT24	24 12	5.796"	5.830"	3/4" 2"
815FT25	25 12-1/2	6.032"	6.070"	3/4" 2"
815FT27	27 13-1/2	6.504"	6.560"	3/4" 2"
815FT29	29 14-1/2	6.978"	7.050"	3/4" 2-1/2"
815FT31	31 15-1/2	7.452"	7.530"	3/4" 2-1/2"
815FT41	41 20-1/2	9.826"	9.930"	3/4" 2-1/2"

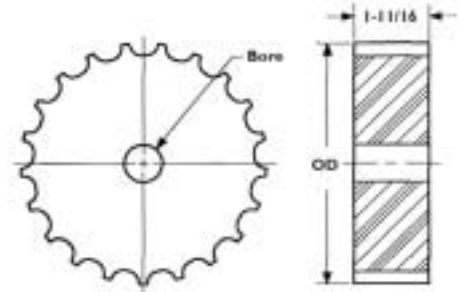

815 Split Flat Top Conveyor Sprocket

P/N	Teeth(Actual)(Effective)	Pitch Dia.	Outside Dia.	Bore(Stock)(Max.)
815FT21S	21 10-1/2	5.089"	5.120"	3/4" 1-1/2"
815FT22S	22 11	5.324"	5.350"	3/4" 1-1/2"
815FT23S	23 11-1/2	5.560"	5.590"	3/4" 1-1/2"
815FT24S	24 12	5.796"	5.830"	3/4" 1-1/2"
815FT25S	25 12-1/2	6.032"	6.070"	3/4" 1-1/2"
815FT27S	27 13-1/2	6.504"	6.560"	3/4" 1-1/2"

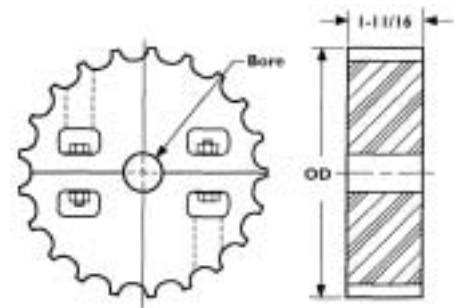

820 Flat Top Conveyor

P/N	Teeth(Actual)(Effective)	Pitch Dia.	Outside Dia.	Bore(Stock)(Max.)
820FT19	19 9-1/2	4.620"	4.610"	3/4" 1-1/4"
820FT20	20 10	4.854"	4.860"	3/4" 1-1/4"
820FT21	21 10-1/2	5.089"	5.120"	3/4" 1-3/4"
820FT22	22 11	5.324"	5.350"	3/4" 1-3/4"
820FT23	23 11-1/2	5.560"	5.590"	3/4" 1-3/4"
820FT24	24 12	5.796"	5.830"	3/4" 2"
820FT25	25 12-1/2	6.032"	6.070"	3/4" 2"
820FT27	27 13-1/2	6.504"	6.560"	3/4" 2"
820FT29	29 14-1/2	6.978"	7.050"	3/4" 2-1/2"
820FT31	31 15-1/2	7.452"	7.530"	3/4" 2-1/2"
820FT41	41 20-1/2	9.826"	9.930"	3/4" 2-1/2"

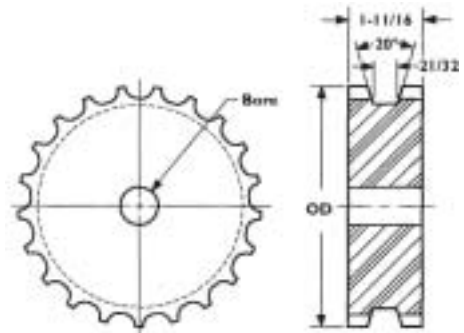

Flat Top Conveyor Sprockets

820 Split Flat Top Conveyor Sprocket

P/N	Teeth(Actual)(Effective)	Pitch Dia.	Outside Dia.	Bore(Stock)(Max.)		
820FT21S	21	10-1/2	5.089"	5.120"	3/4"	1-1/2"
820FT22S	22	11	5.324"	5.350"	3/4"	1-1/2"
820FT23S	23	11-1/2	5.560"	5.590"	3/4"	1-1/2"
820FT24S	24	12	5.796"	5.830"	3/4"	1-1/2"
820FT25S	25	12-1/2	6.032"	6.070"	3/4"	1-1/2"
820FT27S	27	13-1/2	6.504"	6.560"	3/4"	1-1/2"

NOTE!
UHMW-PE Nat. (White)

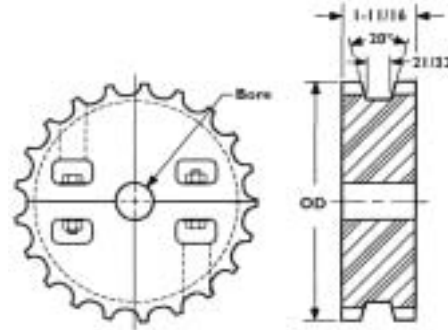

821 Flat Top Conveyor Sprocket

P/N	Teeth(Actual)(Effective)	Pitch Dia.	Outside Dia.	Bore(Stock)(Max.)		
821FT21	21	10-1/2	5.089"	5.120"	3/4"	1-3/4"
821FT23	23	11-1/2	5.560"	5.590"	3/4"	1-3/4"
821FT25	25	12-1/2	6.032"	6.070"	3/4"	2"
821FT27	27	13-1/2	6.504"	6.560"	3/4"	2"
821FT29	29	14-1/2	6.978"	7.050"	3/4"	2-1/2"

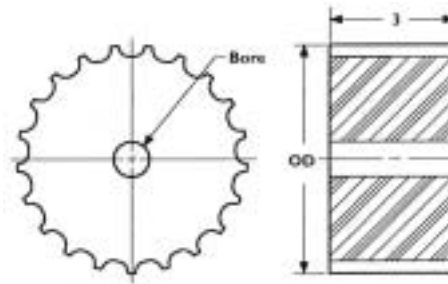

880 Flat Top Conveyor Sprocket

P/N	Teeth(Actual)(Effective)	Pitch Dia.	Outside Dia.	Bore(Stock)(Max.)		
880FT9	9	9	4.386"	4.33"	3/4"	1-3/4"
880FT10	10	10	4.854"	4.82"	3/4"	1-3/4"
880FT11	11	11	5.325"	5.31"	3/4"	1-3/4"
880FT12	12	12	5.796"	5.80"	3/4"	1-3/4"
880FT15	15	15	7.215"	7.26"	3/4"	1-3/4"

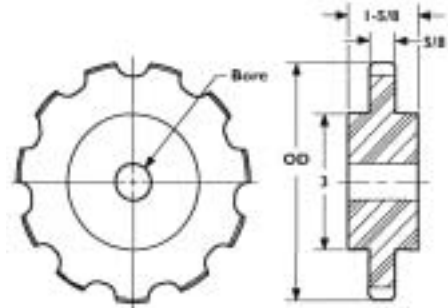

881 Flat Top Conveyor Sprocket

P/N	Teeth(Actual)(Effective)	Pitch Dia.	Outside Dia.	Bore(Stock)(Max.)		
881FT21	21	10-1/2	5.089"	5.120"	3/4"	1-3/4"
881FT23	23	11-1/2	5.560"	5.590"	3/4"	1-3/4"
881FT25	25	12-1/2	6.032"	6.070"	3/4"	1-3/4"

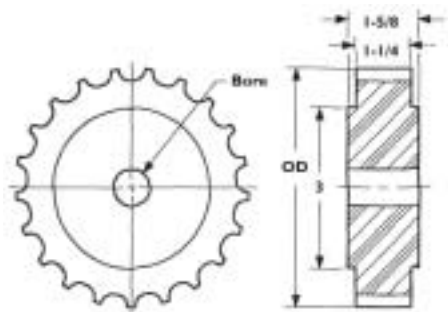

Flat Top Conveyor Sprockets

881 Split Flat Top Conveyor Sprocket

P/N	Teeth(Actual)(Effective)	Pitch Dia.	Outside Dia.	Bore(Stock)(Max.)		
881FT21S	21	10-1/2	5.089"	5.120"	3/4"	1-1/2"
881FT23S	23	11-1/2	5.560"	5.590"	3/4"	1-1/2"
881FT25S	25	12-1/2	6.032"	6.070"	3/4"	1-1/2"

NOTE!
UHMW-PE Nat. (White)

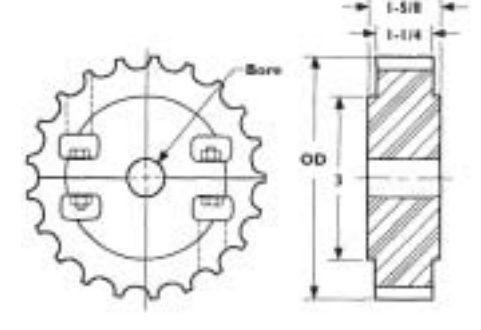

882 Flat Top Conveyor

P/N	Teeth(Actual)(Effective)	Pitch Dia.	Outside Dia.	Bore(Stock)(Max.)		
882FT9	9	9	4.386"	4.43"	3/4"	1-3/4"
882FT10	10	10	4.854"	4.92"	3/4"	1-3/4"
882FT11	11	11	5.325"	5.41"	3/4"	1-3/4"
882FT12	12	12	5.796"	5.90"	3/4"	1-3/4"
882FT15	15	15	7.215"	7.36"	3/4"	1-3/4"

